

Loadpin

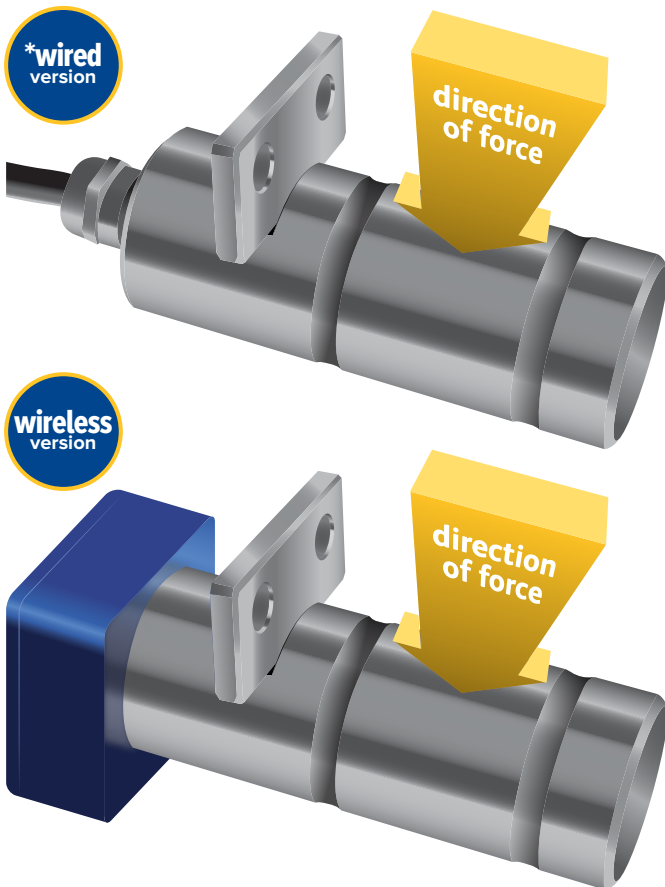

Applications:

- Marine tankers, offshore platforms
- Elevator and floor conveyor testing and certification
- Bearing blocks, pivots and shackles
- Cable laying equipment
- Rope, chain and brake anchors
- Bridge support cables
- Mooring lines
- Pulleys and sheaves
- Crane cables
- Hoisting gear
- Winches
- Design validated by F.E.A.

Please note: Please advise cable configuration on order - Radial or Axial pin exit.
If you require a Loadpin to a particular size and design, download Straightpoint's Loadpin questionnaire and return, POA. www.straightpoint.com/loadpin.html



*Requires connection to Straightpoint's Handheld plus (HHP), Desktop Controller data logging software (DCP10M) or External Amplifier range (SA-3420) that can be configured to provide outputs such as 4-20mA, 0-10v, 0-5v for PLC or data logger integration.

The Straightpoint range of Load Measurement Pins (LMP's) are designed for use in applications where an end of line load cell cannot be used, meaning an integrated solution is required.

Often a customised solution, they are manufactured from high tensile stainless steel and are normally supplied complete with an anti-rotation plate as a cabled or wireless solution.

Built to withstand the harshest environments in industries such as marine and offshore oil and gas, they are suitable for use in exposed situations and can also be supplied to withstand immersion in seawater at extreme depths.

Straightpoint Loadpins are typically connected to Straightpoint's Handheld plus, or may be supplied with a vast array of output formats. These include mV/V, RS-422, RS-485, utilising the ASCII, MODBUS TRU and CAN-BUS protocols or an analogue output such as 4-20mA for PLC integration. All are also supplied with a 10 metre or 32ft cable as standard, however, usable cable length varies greatly with lengths available to 1500 metres or 4900ft, depending on output format.

Please email your enquiry to: sales@straightpoint.com

Also available with hazardous area approval. Zones 0, 1 & 2



ATEX / IECEX
Ex ia II C T4 Ga

Certification numbers:
LP ATEX
 IECEx SIR 16.0041X / Sira 16ATEX2108X
SW-HHP ATEX
 IECEx SIR 15.0072X / Sira 15ATEX2196X

Add 'ATEX' to the part number when ordering ATEX/IECEX products. For example: LP500KG-ATEX

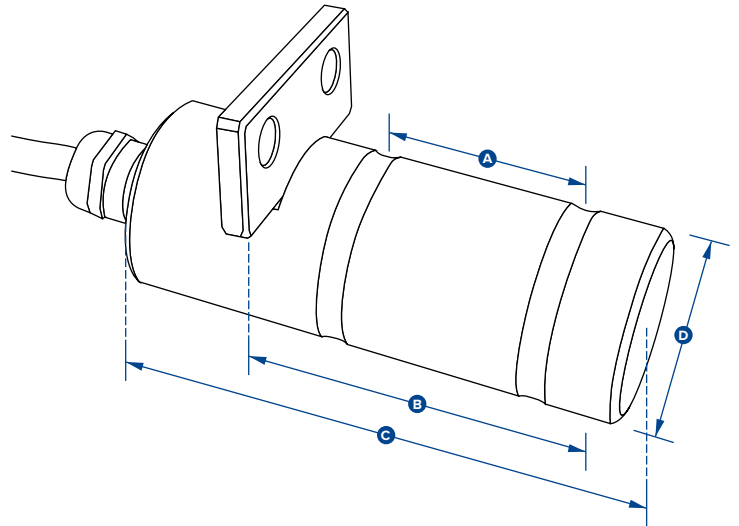

Part Numbers														
SP	LP500KG	LP1T	LP2.5T	LP3.5T	LP6.5T	LP15T	LP25T	LP50T	LP100T	LP250T	LP500T	LP750T	LP1000T	LP1500T
Crosby	2789276	2789277	2789278	2789279	2789280	2789281	2789282	2789283	2789284	2789285	2789286	2789287	2789288	2789289
Capacity	500kg 1100lb	1000kg 2200lb	2.5te 5500lb	3.5te 7700lb	6.5te 14000lb	15te 33000lb	25te 55000lb	50te 110000lb	100te 220000lb	250te 550000lb	500te 1100000lb	750te 1650000lb	1000te 2200000lb	1500te 3300000lb
Resolution	0.2kg 0.5lb	0.5kg 1lb	0.001te 2lb	0.001te 2lb	0.002te 5lb	0.002te 5lb	0.005te 10lb	0.01te 20lb	0.05te 100lb	0.1te 200lb	0.2te 500lb	0.2te 500lb	0.5te 1000lb	0.5te 1000lb
Units	kgs, tonnes													
	lbs													
Weight	0.9kg 0.4lb	1kg 0.5lb	1.2kg 0.9lb	1.4kg 1.3lb	2kg 2.6lb	3.1kg 5lb	5.6kg 10.3lb	8.6kg 18lb	11.8kg 24lb	29.8kg 64lb	79.2kg 172lb	146kg 319lb	275kg 603lb	389kg 854lb
Safety Factor	300% of SWL													
Operating Temp	-20°C to +70°C or -4°F to 158°F													
Accuracy	±1% of full scale													
Protection	IP67 [IP68 available as an option] or NEMA6 [NEMA6P available on application]													
Dimension A	24 0.94"	35 1.38"	45 1.77"	50 1.97"	63 2.48"	75 2.95"	89 3.50"	102 4.02"	110 4.33"	130 5.12"	225 8.86"	295 11.61"	360 14.17"	430 16.93"
Dimension B	36 1.42"	49 1.93"	70 2.76"	75 2.95"	95 3.74"	114 4.49"	152 5.98"	178 7.01"	190 7.48"	220 8.66"	370 14.57"	500 19.69"	612 24.09"	731 28.78"
Dimension C	70 2.76"	80 3.15"	100 3.94"	105 4.13"	125 4.92"	150 5.91"	195 7.68"	225 8.86"	230 9.06"	300 11.81"	440 17.32"	590 23.23"	712 28.03"	832 32.76"
Dimension ØD	20 0.79"	20 0.79"	25 0.98"	30 1.18"	40 1.57"	50 1.97"	63 2.48"	75 2.95"	88 3.46"	125 4.92"	170 6.69"	200 7.87"	250 9.84"	275 10.83"